

Gennaker pole kit

Assembly instruction for gennaker poles

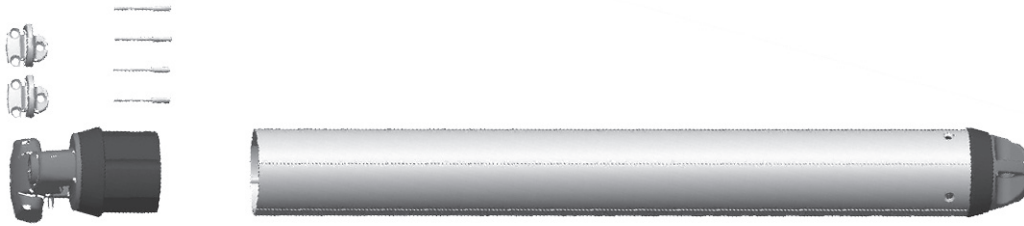

Tools Required:

Saw	Screwdriver torx
Drill	Hammer
Ø 6.5 mm drill bit	Pop Rivet Gun

Parts included in kit

Extrusion with outboard end fitted
Inboard end
Fasteners
Pad eyes (screw M6 not incl.)

Assembly

1. Find the correct length, see table 2 (DBS + USL).
When in doubt, contact dealer.
2. Mark the length of the extrusion, see table 1 for reductions.
(Use a paper as a guide as fig. 1). Cut the extrusion.
3. Mark the holes for the rivets, according to table 1.
4. Drill the holes with a Ø 6.5 mm drill bit.
5. Fit the inboard end with pop-rivets and punch out the mandrel heads.

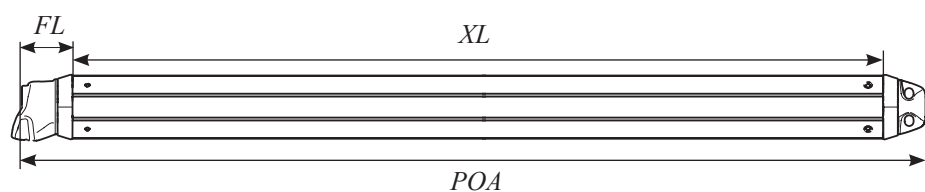
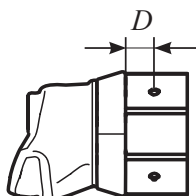
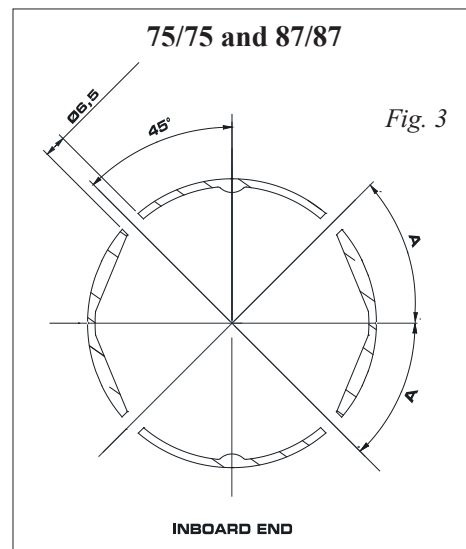
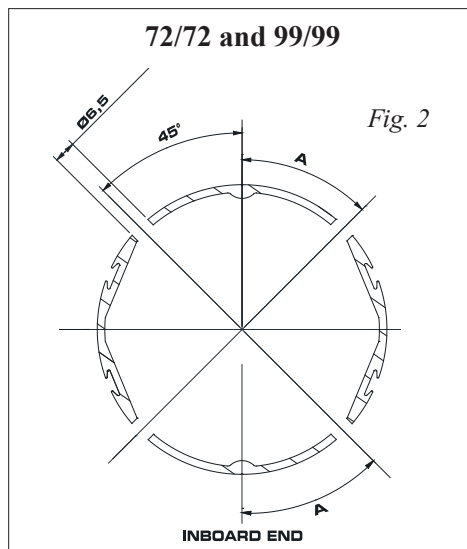
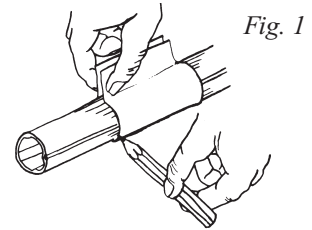

Extrusion	A	D	Extrusion length
72/72	29	40	XL = POA - 78
75/75	30	40	XL = POA - 78
87/87	34	20	XL = POA - 122
99/99	39	20	XL = POA - 158

Tab. 1

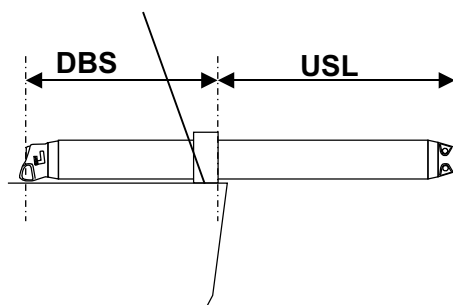

Dimensioning (Not applicable for "Code 0" = straight luff)

Tab. 2

RM	Approx. Displ. (Tonnes)	Aluminum Max unsupported length. USL				Carbon Max unsupported length. USL		
		72/72	75/75	87/87	99/99	76/76	88/88	89/89
8	1.7	1280				1500		
10	2.1	1090				1500		
12	2.4	960	1700			1462	1500	
14	2.8	860	1520			1311	1500	
16	3.1	790	1390			1194	1500	
18	3.4	720	1280	1640		1098	1453	1500
20	3.7	670	1180	1520		1020	1349	1500
25	4.5	570	1010	1300	1710	871	1152	1452
30	5.2	500	890	1140	1510	76	1013	1277
35	5.9		800	1020	1350	687	909	1145
40	6.7		730	930	1230	626	827	1043
45	7.3		670	850	1130	576	762	959
50	8.0		620	790	1050	535	707	891
55	8.7		580	740	980		661	833
60	9.3		550	700	930		622	783
65	10.0			660	870		588	740
70	10.6			630	830		558	703
75	11.3			600	790		531	669
80	11.9			570	750		508	640
85	12.5			550	720			613
90	13.1			530	700			597
95	13.8				670			589
100	14.4				650			547
105	15.6				630			528
110	16.0				600			511
115	16.1				590			
120	16.7				570			
125	17.3				550			
130	17.9				540			
135	18.5				520			
140	19.0				510			
145	19.6				500			
150	20.2				490			
155	20.7				480			
Min. Distance between support. DBS (mm)		580	600	700	800	620	710	720
MSL at inner end (kn)		2.9	4.9	5.4	6.2	2.0	2.4	2.9

MSL = Max Service Load. based on minimum DBS. MSL at bow bracket = MSL at inner end x (1 + DBS/USL)



www.seldenmast.com